

# ED percussion stud

Fixing in concrete without pre-drilling.



Fixing of reinforced pipes



Fixing of perforated cut-outs

Concrete

## ADVANTAGES

The robust ED hammer stud can be installed in concrete

with the striker SZE without preforatura. This allows an installation fast.

The shock protection of the SZE cooler offers the best protection hand and ensures an installation-sure ion.

## APPLICATIONS

To fix:

- Gaffette
- Perforated cut-outs such as LBK,
- LBV

## OPERATION

The ED percussion nail is installed with the striker SZE.

The striker retainer ring holds firmly in place the nail during the installation procedure.

The nail can be fixture direct-mind in the concrete.

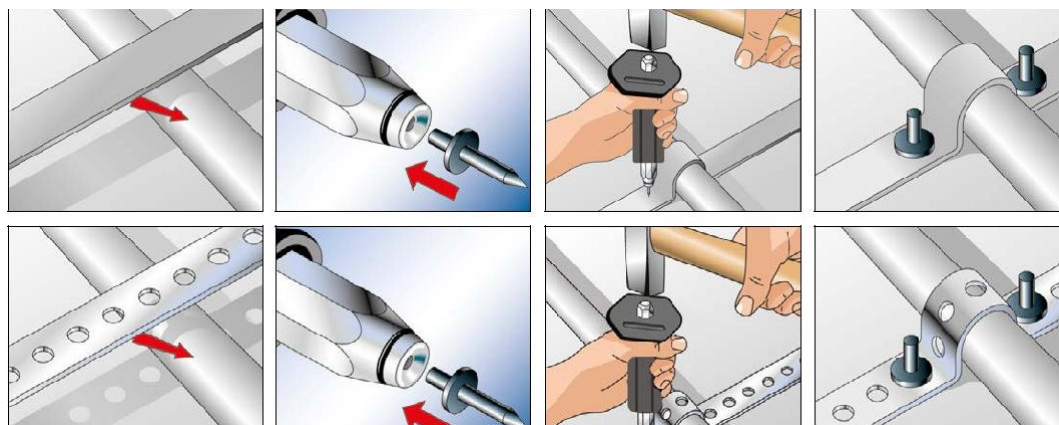



# ED percussion stud

## TECHNICAL DATA

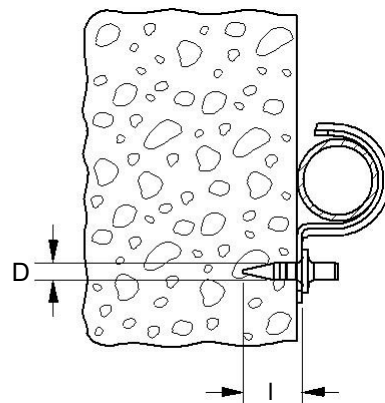

ED percussion stud

Percussion nail **ED 18 BOX**

	steel galvanized	Length	Diameter	Packaging
Product	Art. No	l [mm]	D [mm]	[pz]
ED 18	079815	18	4,0	200
ED 18 BOX	513848	18	4,0	600
ED 22	014570	22	4,0	200

## TECHNICAL DATA



SZE 18 percussion pin striker,

Spare parts kit for **SZE**

Product	Art. No	Packaging
		[pz]
SZE 18	552149	1
Spare parts kit SZE	552150	3

